

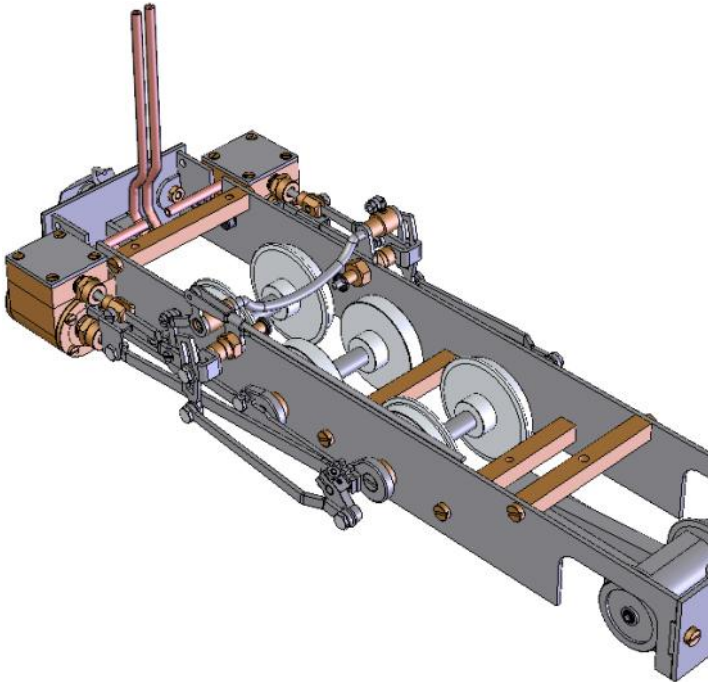

Modular Locomotive System Instruction Manual *for* HBK20 Fowler Chassis Kit



Roundhouse Engineering Co. Ltd.

Units 6-10 Churchill Business Park.

Churchill Road, Wheatley.

Doncaster. DN1 2TF. England.

Tel. 01302 328035 Fax. 01302 761312

Email. mail@roundhouse-eng.com

www.roundhouse-eng.com

HBK20 0-6-2 Fowler Chassis Kit

Introduction

These instructions cover the construction of an 0-6-2 chassis with Walschaerts type valve-gear. The valve gear is of a simplified design which does not make use of a combination lever.

No machining is necessary, though certain parts may require the use of hand tools to obtain a good fit and, a small number of holes require drilling during the construction of the valve-gear.

In the following pages, we will take you through the construction step by step with the aid of both written instructions and diagrams, just as we build the locomotives in our works. We have made the instructions as clear and concise as possible and have tried to show where and what problems are likely to be encountered and how to overcome them. This is not a 'build it in one evening' kit, however, anyone with a little patience and care can build a working steam locomotive to be proud of using the minimum of hand tools.

Before starting to actually assemble the chassis, check the contents against the check list on the back page and read through these instructions fully so that you identify all parts and understand where each is fitted. Refer to diagrams at all times as these will make it clear which way round certain parts go and what holes are used. From long experience, we have found that with this type of working model, it does not pay to work to 'close fits' in certain areas when assembling. Pay attention to any clearances and slotted holes etc. otherwise you may find that the first time you steam it up it will not run. The reason for this is expansion. A lot of heat is used to generate the steam and some of this is passed through the loco causing all parts to expand slightly. As several different materials are used and some items get hotter than others, expansion is not uniform throughout. What seems perfectly free running when cold can lock up solid when hot, unless allowances have been made.

The more adventurous builders may wish to use this chassis kit as a basis for their own model and, there are many ways in which it can be modified to suit a different design. We do however suggest that, unless you know exactly what you are doing, you should not alter in any way the relationship between cylinder's, valve-gear and drive axle. The geometry of the valve-gear is quite precise and any alteration could have a bad effect on the smooth running of the finished engine.

Please note:- drawings and pictures in this manual are not to scale.

Tools Required

The following tools will be required during construction:-

Small and medium sized screwdrivers. Pair of long nose pliers.
Small (Swiss) files (needle files). Drill with 1.6mm or 1/16" drill bit.

Small clamp (tool makers clamp or similar).

Assembly of the Main Frames

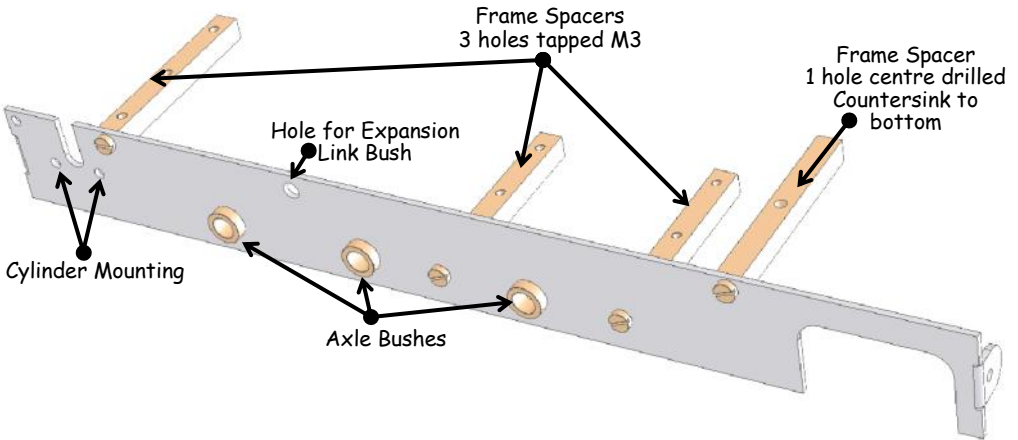

Refer to the diagram above and note the position of the four frame spacers. The rearmost frame spacer has a plain hole that is countersunk on one side. The countersunk side should be towards the underside of the chassis. The frame spacers should be positioned as shown, with the holes sitting vertically.

Take the left hand main-frame and, making sure that the bosses of the axle bushes are pointing to the outside, fit the four frame spacers to the inside face of the frame using the M3 brass screws.

Offer up the right hand mainframe, again with the axle bush bosses pointing outwards, and screw it to the other side of the frame spacers with more M3 brass screws.

Now that the main frames and frame spacers have been assembled, this is a convenient point at which to paint the frames and buffer beams. This may be done with either cellulose or enamel, both of which are readily available in spray cans for a good finish. Prior to painting, any surface rust should be removed and the frames degreased to remove the anti rust oil with which they are coated.

BUFFER BEAMS & CENTRE BUFFERS

The Front and Rear Buffer Beams are identical.

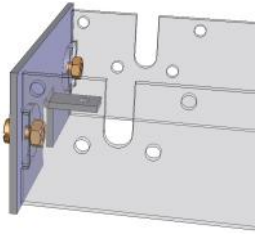

Using the M3 x 6 brass screws and nuts, fit the Buffer Beams to the frames, making sure the brackets point inwards.

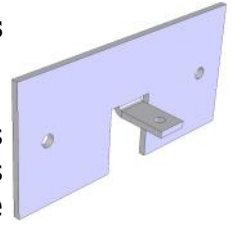

The centre buffers can now be fitted. Slide one through the slot in the buffer beam and line up one of the holes with the tapped hole on the bracket. Secure with a M3 brass screw. The buffers are set at a centre height of approximately 25mm which is generally the accepted norm. If the tender is to be fitted, the rear buffer beam is replaced by a draw bar and drag beam included in the tender kit.

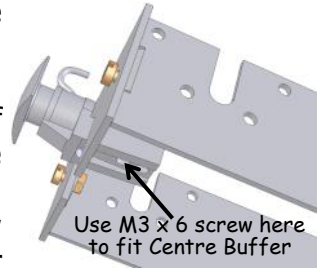

WHEELS & AXLES

The wheels and axles can now be fitted after first cleaning any paint out of the axle bushes and checking for free running by pushing an axle only, through each pair of bushes. First, check that each end of an axle will easily pass through the axle bush. If not, gently file the round end of the axle to remove any burrs that may be there.



Start with the rear wheels first. Push an axle partly through one axle bush, slip two flanged wheels on from inside the frame, with the bosses and grub screws both towards the inside. Now push the axle through the other bush. Don't fit the front and middle axles yet. We will come to these later. The next step is to fit the outside cranks to this rear axle.

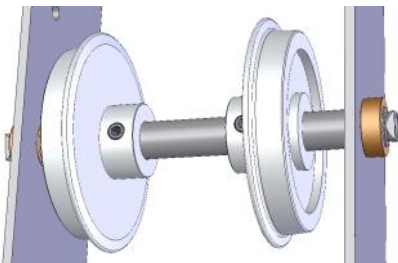

OUTSIDE CRANKS & AXLES



Outside Crank

The outside cranks have square holes in the centre to ensure the 'quartering' is correct. One side of the centre hole is countersunk (CSK), and should be to the outside, so that the 4BA CSK fixing screw finishes up flush with the outer face. The two outside cranks that we are going to fit to the rear axle are the ones with the plain crank pins fitted.



Outside Crank with Plain Crank Pin

Now convention says that the right hand side should lead. All this means is that when the model is running forward, the right hand crank is 90 degrees, or a quarter of a revolution in front of the left; hence the term 'quartering'. We always observe this, though it would make no difference at all to the running if it were the other way round.

Fit an outside crank on each end, using the two that already have plain crank pins fitted. The crank pins should of course be pointing outwards. Ensure that the cranks are tightened on well, using the 4BA CSK steel screws. It may help to lightly press the cranks on by gripping between the jaws of a vice or 'G' clamp before actually fitting the screws.

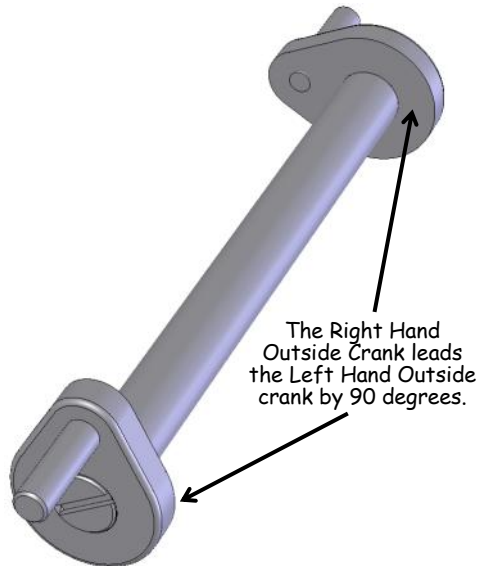

The Right Hand Outside Crank leads the Left Hand Outside crank by 90 degrees.

Check the end float in the axle by sliding it from one side to the other. If this movement is excessive, fit one of the 1/4" bore steel washers onto the axle between the outside crank and the axle bush on the right hand side only. As a general rule, with the axle held firmly over to one side, if a washer can be

easily slipped into the gap between outside crank and axle bush and still leave a little space for side movement, then it should be fitted.

Repeat for the front and middle axles using the plain outside cranks and making sure that the un-flanged wheels are fitted to the centre axle. Not having a flange on the centre wheels enables the finished locomotive to navigate much smaller track curves. Indeed, the finished model will run around 2ft radius track. The bigger the track radius the better. When laying track try and aim for at least 3ft 6inch radius if possible.

The driving wheels are moveable on their axles and are locked in place by a small grub screw. They should be adjusted so that the brass back-to-back wheel gauge supplied will just slip between their inner faces. Ensure that the wheels are evenly spaced relative to each side frame. Do not over tighten the grub -screws. Note that the wheel gauge can be used for either 32mm gauge (SM32) or 45mm gauge ('G' scale) depending on which end of the back-to-back wheel gauge is used.

Make sure that all axles rotate freely.

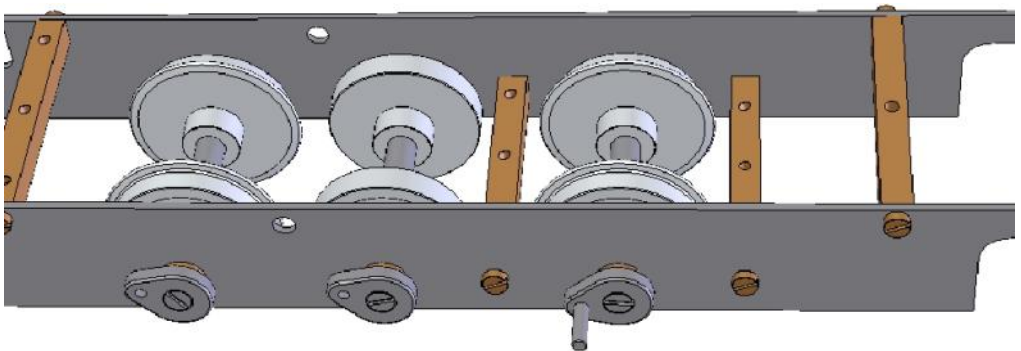

Coupling Rods

For the moment, forget the centre axle. We will treat the chassis as an 0-4-0. This makes it easier to find any tight spots. Note:- The middle hole in the coupling rod is not in the centre of the rod - it is slightly nearer the front hole. Make sure the rod is pointing the correct way or the centre hole will not line up.

Place a 5BA steel washer over one of the rear crank pins and then push a coupling rod on after it, checking that the two lugs are pointing to the top. Connect the front end of the coupling rod to its outside crank using a short crank pin with another 5BA steel washer between the rod and the crank.

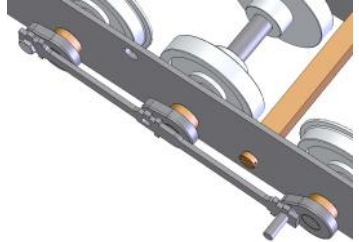

Repeat for the opposite side.

Slowly rotate both front and rear wheels together and feel for any tight spots. If it sticks at all, look which side has its outside cranks at or near front or rear dead centre (that is pointing to the front or rear of the chassis). On that side remove the front crank pin and check to see how the hole in the coupling rod aligns with the hole in the outside crank. You may find that, with the cranks in the position where you felt the tight spot, the hole in the coupling rod is offset to the front or rear of the hole in the crank. Slightly elongate the coupling rod hole in this direction with a small round file to stop the coupling rod binding on the short crank pin. Remove only a very small amount at a time and keep trying it until the wheels rotate freely without any tight spots.

Now, fit a short crank pin and washer to one side only through the centre hole in the coupling rod and into its outside crank. As before, rotate the wheels and check for any tight spots. If there are, then this side centre hole will require slightly elongating as before. When this is running freely, repeat for the centre hole on the other side. In this way, you should end up with all six cranks connected and the wheels running freely. Don't forget that a 5BA steel washer should be between the coupling rod and the outside crank on all six cranks.

CYLINDERS

You may find access easier if you remove the front buffer beam and centre buffer.

Using two socket cap mounting screws and washers, fix one cylinder block to the chassis through the 2 outer holes of the 4 on the frame. Make sure that the washer fits between the head of the socket screw and the frame. The copper exhaust pipe should be bent forwards and slightly up out of the way.

The exhaust pipes are screwed into the cylinder blocks, so take care when bending them not to snap the thread where it enters the cylinder block. Don't worry about the final position of the exhaust pipes at this stage. Check that the cylinder blocks are level to the frames and then tighten up the socket screws with the Allen Key provided.

Place the slide valve onto the top of the cylinder block, so that it is covering the three holes in the centre. Lay one of the black valve chest 'O' rings over the slide valve, so that the slide valve is sat in the middle of the 'O' ring. Take one of the valve chests (either one as they are both the same), and carefully place this over the top of the slide valve, so that the valve nut fits into the slide valve, and the 'O' ring fits into the recess at the bottom of the valve chest. Take care here that the 'O' ring does fit into the recess as it can easily move and become trapped under the edge of the valve chest. Also check that the valve nut has the round side facing uppermost, and that the flat side is located in the slide valve slot.

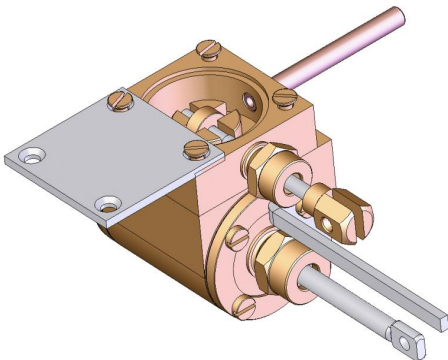

Using just two of the brass countersunk screws, half fit the valve chest cover so that it is offset to the outside, as shown in the opposite diagram. This allows you to see into the valve chest to adjust the position of the slide valve later on, when setting the timing.

Do not fit the top valve chest 'O' ring at this stage.

If you intend using the ROUNDHOUSE Fowler gas fired boiler kit and have already purchased it, now is a good time to fit the stainless steel superheater which is included with it. If not, you can continue construction of the chassis and fit the superheater at a later stage, but you will need to fit it before an air or steam test can be carried out. If you are fitting your own boiler to this chassis, the superheater is available from ROUNDHOUSE as a separate part if required.

The superheater has a 'T' connector silver soldered to one end which connects the two cylinders. Slide one of the 2 hexagon union nuts onto the steam inlet pipe followed by an 'O' ring. Now slide one end of the superheater 'T' on and loosely screw the union nut onto it with the 'O' ring inside. The superheater should be pointing upwards for now. Put a union nut and 'O' ring onto the inlet pipe of the second cylinder and fit this to the chassis ensuring that the inlet pipe fits into the open end of the 'T'. Loosely screw the second union nut onto the 'T' then position it centrally between the frames and tighten up both union nuts just sufficient to squeeze the 'O' rings a little. Do not over-tighten or you will crush and damage the rubber 'O' rings.

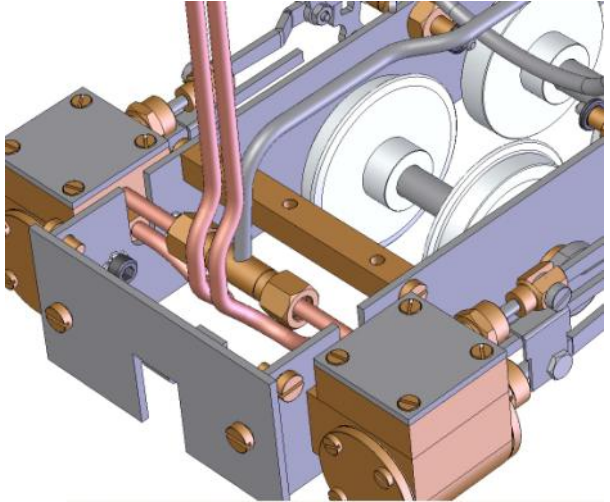

Extend both piston rods and check that they are parallel to the top or bottom edge of the chassis, or more simply, that they are pointing straight at the centre of the rear axle. If not, slacken off the two cylinder mounting screws that you have just fitted through the frames, move the cylinder round a little until it is in line and retighten the screws.

CONNECTING RODS

Remove one of the crosshead screws and stainless steel crossheads from the end of the piston rod. As with the coupling rods the two lugs at the rear of the connecting rod should point upwards. The smaller, rounded end fits to the piston rod and the larger squared end fits over the rear crank pin. The rods are cranked because the piston rod is further out from the chassis than the outside crank. Fit a 5BA steel washer over the rear crank pin and then slide the connecting rod 'big end' on. Push the crosshead screw through the stainless steel crosshead and then through the connecting rod 'little end' and finally screw it into the end of the piston rod. Repeat for the other side then rotate the wheels to check that it all operates smoothly. You will now feel the resistance of the pistons sliding up and down the cylinders, though there should be no tight spots.

We are now ready to move onto the valve gear.

Construction of the Walschaerts type valve-gear

Refer to the drawing opposite showing an exploded view of the left hand valve gear.

Fit the return cranks first as these will then retain the coupling and connecting rods, not forgetting yet another 5BA steel washer between them and the connecting rods. The positioning of these is critical to the correct running of the engine and when the valve-gear is all assembled and tested, they will be pinned

in place to prevent any movement. For the moment however just clamp them in position using the steel screws and nuts provided.

Refer to the diagram on the left and note that the return crank always leads the crank pin in forward rotation. This shows the left hand side return crank. The right hand side is a mirror

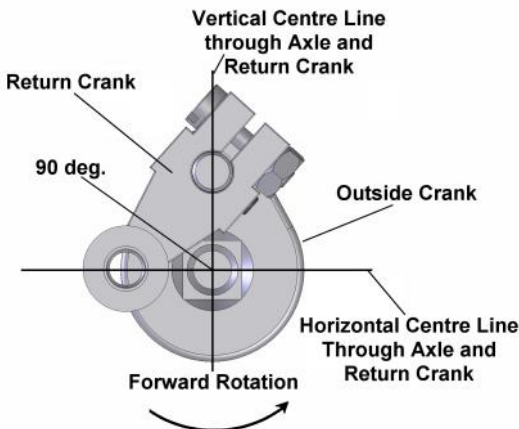

Assembly of Walschaerts type valve-gear

- | | | |
|--------------------------|------------------------------------|---------------------|
| 1). Radius Rod. | 2). Lifting Link. | 3). Lifting Arm. |
| 4). Expansion Link Bush. | 5). Weigh Shaft Bracket (Penguin). | 6). Weigh Shaft. |
| 7). Starlock Washer. | 8). 2BA Nut. | 9). Expansion Link. |
| 10). Eccentric Rod. | | |

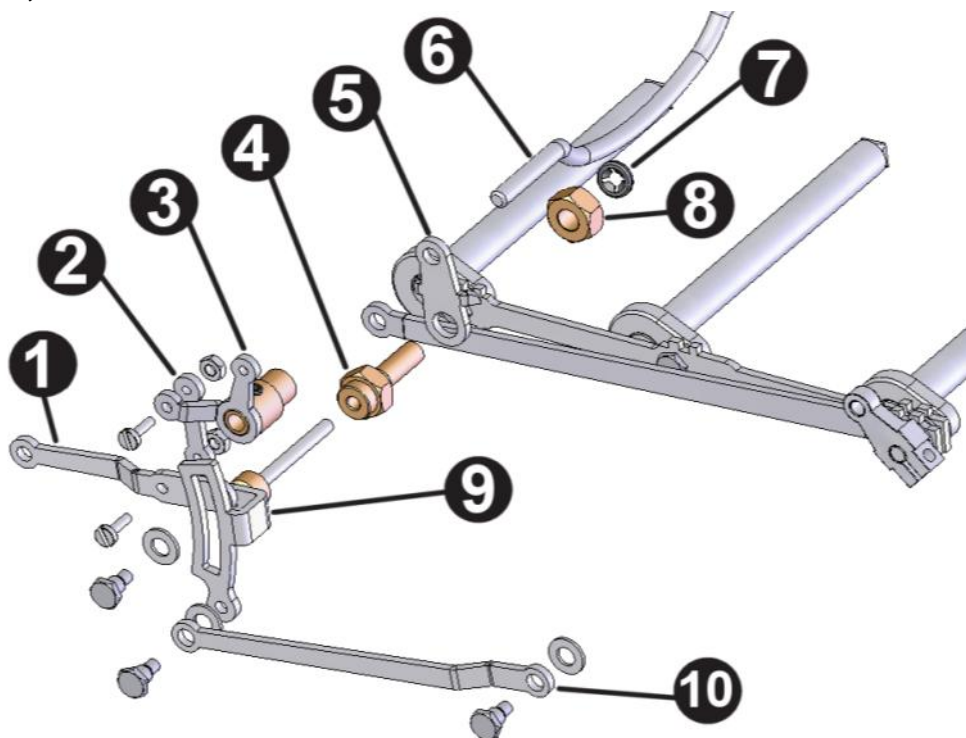

image of this, so that the return crank is still leading the crank pin by 90 degrees in forward rotation.

WEIGH SHAFT

The weigh shaft can now be assembled. Take one weigh shaft bracket or 'Penguin' bracket as they are commonly known at ROUNDHOUSE (use your imagination here) and push the threaded part of an expansion link bush through the larger (bottom) hole.

Note that the smaller top hole is offset and, when bolted to the frame, will be slightly in front of the expansion link pivot point.

The two small 'wings' sticking out from the

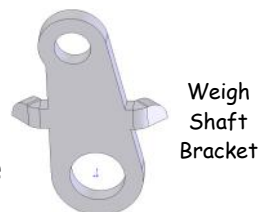

sides of the 'Penguin' brackets should be bent backwards slightly using a pair of pliers. These will locate on the top face of the chassis to keep the bracket in position. Remove the expansion link from the bush, and unscrew the nut. Push the expansion link bush through larger hole in the 'Penguin' bracket and then through the hole in the chassis. Refit the brass nut on the inside of the chassis. When tightened up, the 'Penguin' bracket is held tight against the outside of the frame with its 'wings' resting on the top edge and the top hole leaning slightly forward. Do not over tighten the nut as the bush may break.

Before repeating the procedure with the other side, first slide the weigh shaft through the top hole of the 'Penguin' bracket already fitted. Slide the remaining 'Penguin' Bracket over the other side of the weigh shaft and then secure to the frame as before, with the expansion link bush and nut.

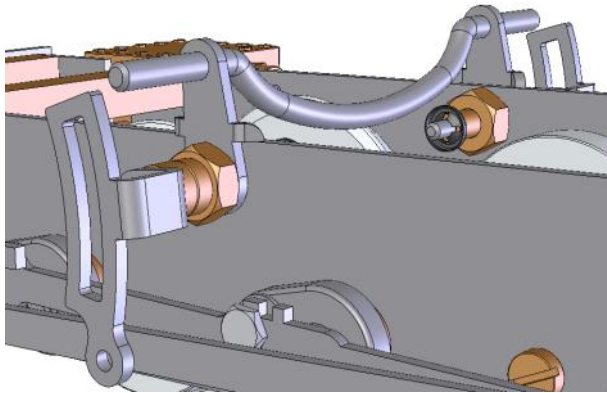
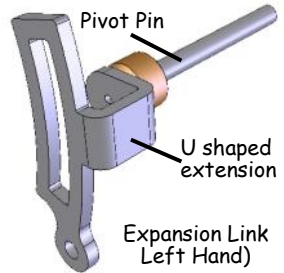

The pivot pins on the expansion links can now be pushed through the bushes. Note that these are handed and, with the tapped hole to the bottom, the U shaped extension that connects the expansion link to its pivot pin should be to the rear.

Starlock washers are pushed onto the ends of the pivot pins between the frames to hold them in place, but should not be pushed on so far that they prevent free rotation.

If you look closely at the Starlock washer you will see that there is a cross cut into the centre and that the edges bend inwards slightly and form a cone on the other side. The 'cone' side should be pushed onto the pivot pin using a pair of long nosed pliers.

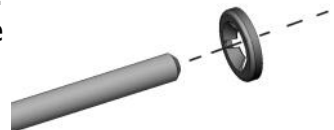

ECCENTRIC RODS

The eccentric rods can now be fitted to connect the return cranks and the expansion links. These rods are slightly tapered and the thicker end has a 'joggle'. They are attached by 6BA shouldered crank pins with a 5BA steel washer between. The thicker end goes to the rear with the 'joggle' outwards.

This is a good point to check that everything works freely when the wheels are rotated. Check for tight spots or anything misaligned.



RADIUS RODS

Before fitting the Radius Rods, the crank pins have to be prepared. This simply entails screwing a crank pin into the tapped hole in the thick end of the radius rod and filing off the excess thread that sticks through at the rear. File the thread off flush to the back then remove the screw again.

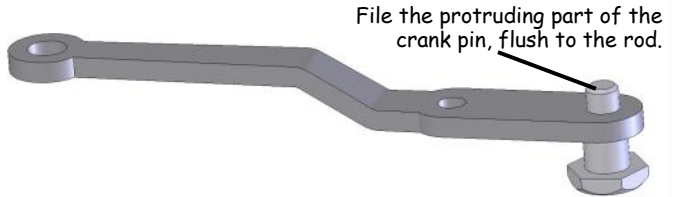

Take the prepared crank pin, fit a steel washer then pass it through the curved slot in the expansion link and screw it into the tapped hole in the radius rod. Note that the radius rod is also 'joggled'. This time the 'joggle' should be inwards to bring the thinner end of the radius rod nicely in line with the valve spindle on the cylinders.

Fit the thinner end into the forked end of the valve rod and screw the steel screw (supplied with the cylinders) through the hole to connect up.

You now have the main links connected. Check that the radius rod is at the bottom of the curved slot in the expansion link.

Rotating the wheels now should result in the valves at the top of the cylinders being moved backwards and forwards. What is needed now is a means of raising and lowering the radius rod and holding it in position so we now must assemble the lifting links, etc.



Lifting Arm
Left side

Slide the left hand lifting arm onto the left hand end of the weigh shaft. Note that the lifting arms are handed and the left hand has a second arm which points upwards and slightly forwards where the reversing rod will connect.

Using the M2 steel screws, connect the lifting arm to the radius rod. The screws pass through the holes in the arm and radius rod and screw into tapped holes in the lifting link. Do not tighten the screws, but leave a small gap to allow for movement as the lifting gear operates. Fit a M2 steel nut to the screws at the back of the lifting link and tighten these up.



lifting link

The steel reversing rod and Quicklink connector can be used to hold things in position while they are pinned. Spring apart slightly the Quicklink connector so that it attaches through the top hole in the lifting arm (the one pointing upwards).

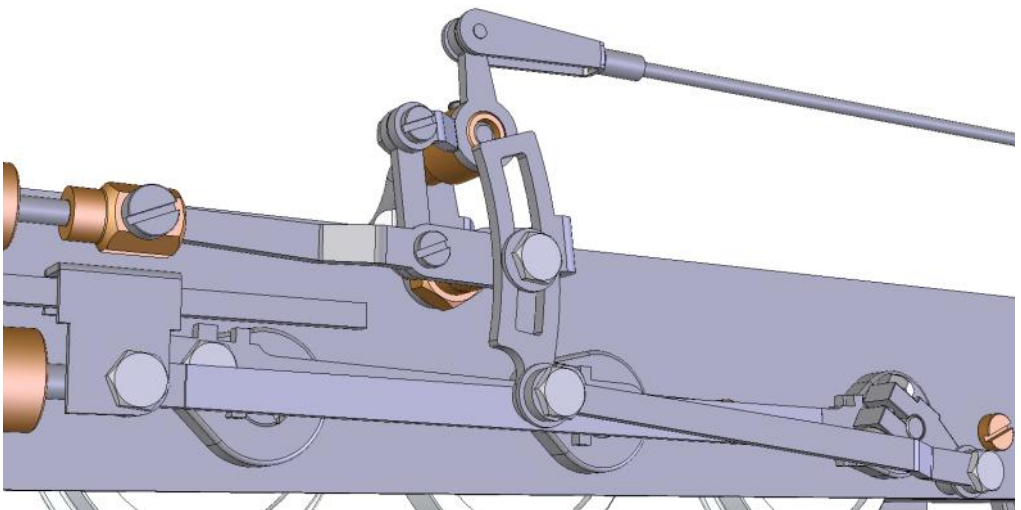

Set the valve-gear to mid gear, that is, operate the lifting arm until the hexagon screw that drives the radius rod and slides up and down in the expansion link is exactly in the centre of the curved slot. Check this by rotating the wheels and watching the radius rod. There should be no fore and aft movement whatsoever. Keeping it in this position, clamp the end of reversing rod to the side of the chassis with a toolmakers clamp or similar. Double check the position of the radius rod.

Tighten the grub screw in the top of the lifting arm casting boss to lock it in place. Keeping everything clamped in place, assemble the right hand lifting arm and link and set that side to mid gear.

Hold the links in position and tighten the grub screw as before. Take great care with this operation and ensure that the radius rods on both sides are exactly in mid gear, or they will be lifted unevenly when the lifting arms are operated.

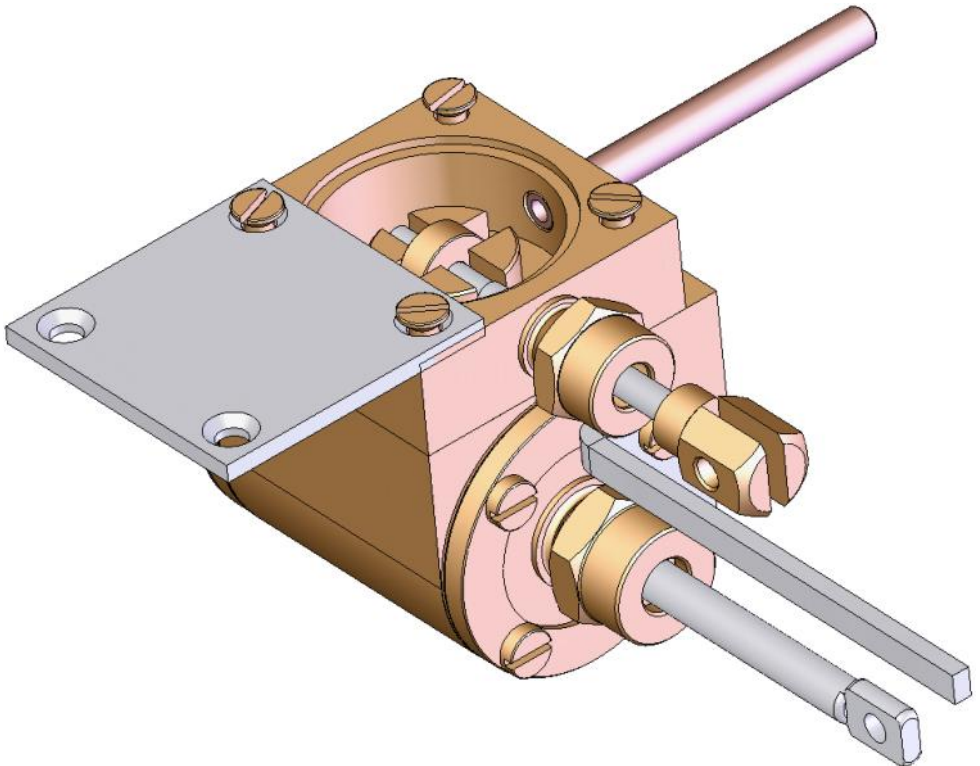

The valve-gear is now assembled and we can move on to timing before finally pinning the return cranks in position.

VALVE TIMING

This is adjusting the valve position so that it opens and closes at the correct time and is checked visually by watching the valve movement. To enable you to do this, remove the valve chest covers (four screws in each) and replace two screws and the valve chest cover loosely, as shown below, to hold the valve chest in position. NOTE: the valve nuts are flat on the bottom and care must be taken to ensure that the flat side remains to the bottom. If a valve nut rotates the slide valve will be clamped firmly onto the steam ports, and the valve spindle may be bent.

With the valve-gear still clamped in mid gear and the valve chest covers removed from the cylinders, look down into the valve-chests and note the position of the slide valves.

They should be sitting centrally over the steam inlet ports, covering both. If they are not, disconnect the radius rod from the valve spindle fork end and rotate the valve spindle to screw the slide valve in the desired direction. Re-connect the radius rod and re-check position.

There may be a small amount of fore and aft free movement of the valve if the spindle is moved with the fingers, which just uncovers the steam ports. If this is the case, adjust the valve position so that the ports are opened an equal amount when moved thus. Repeat this with both sides until the valves are correctly positioned.

Unclamp the end of the reversing rod and move it forwards so that the radius rods are lowered in the expansion links. Position them near but not right at the bottom and clamp the reversing rod in place again. The valve gear is now set for forward running so, rotate the wheels by hand in a forward direction and watch the slide valve movement.

The edge of the steam ports should become visible (crack open)

as the crank pin on the drive axle is at dead centre. The front steam port should be cracking open at front dead centre and the rear steam port at rear dead centre.

If the return cranks are correctly positioned, this should be the case. If not, rotate the return crank on the crank pin a very small amount and re-check.

When satisfied that the timing is as close as you can get it, the valve chest covers can be fitted. Place a second 'O' ring into the top recess of the valve chest. Ensure that the 'O' ring seals between the cylinder blocks and the valve chests, and between the valve chests and the valve chest covers, are fully in their respective recesses before tightening down the valve chest covers. The chassis can be test run on compressed air if available to check operation. Don't forget that the radius rod should not be raised or lowered right to the ends of the expansion link slot and use plenty of oil on all working parts. Slight unevenness in running can normally be overcome by slight adjustments when the locomotive is running under its own steam, see fine tuning.

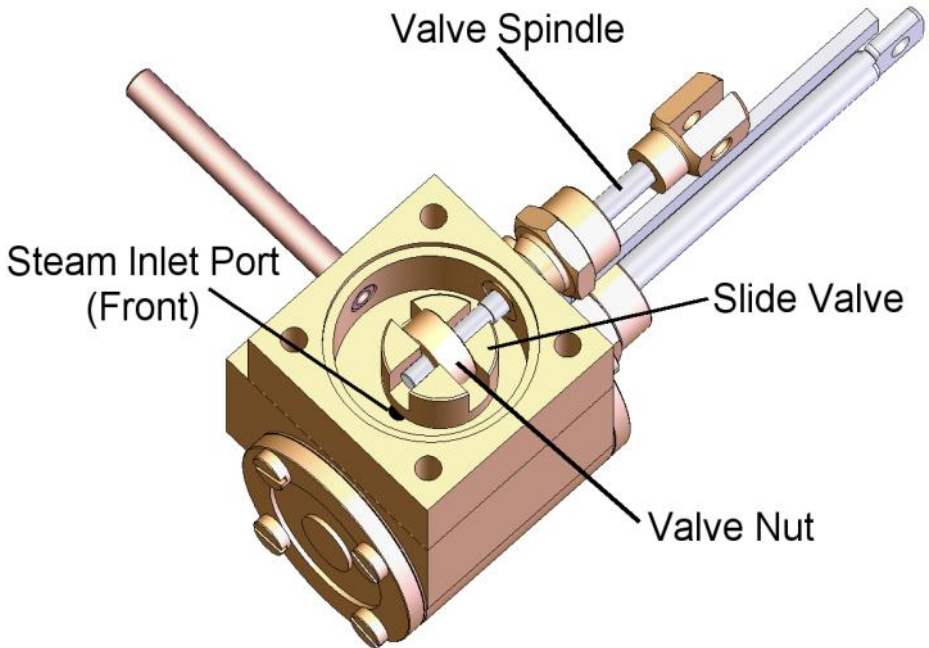

Finally, the return cranks should be drilled and pinned to ensure that they do not move in service. To do this, place the chassis on the work top and rotate the wheels to position the outside crank towards the top of its movement, with one of its sides sitting horizontal. Place a 3/4" thick block of wood underneath the return crank to support it. Using a sharp 1.6mm drill, drill a hole vertically downwards through the centre of the return crank, through the crank pin and out of the bottom.

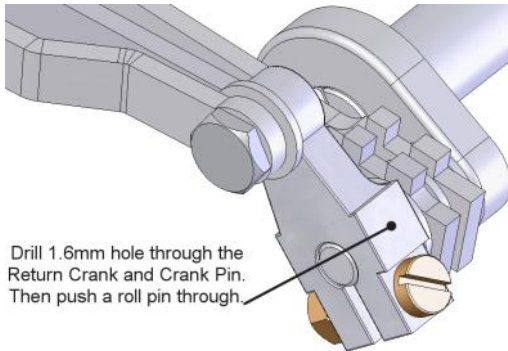

Drill 1.6mm hole through the Return Crank and Crank Pin. Then push a roll pin through.

Push a roll pin through this hole to lock this side in place then repeat for the other side.

Make sure that the return cranks do not move during this operation.

Note, If you do not have a superheater fitted and are therefore unable to test the running of your chassis at this stage, do not pin the return cranks in place. Wait until you are able to carry out a test run.

REVERSING LEVER

A set of parts are included to construct a reversing lever for manual operation that can be mounted on the footplate. Refer to the diagram below which shows how the reversing lever is assembled. Check that the Reversing Lever Arm is orientated as shown in the diagram below. Then attach the push rod connector to the Reversing Lever Arm with the Starlock Washer as shown. Place the spring over the Long Crank Pin and push the threaded end of the Long Crank Pin through the hole in the bottom of the Reversing Lever Arm and screw into the threaded hole in the Reversing Lever Base. Fit a M2 screw and nut to the top central hole in the Reversing Lever Base which will allow the Lever to stay at mid gear. Now fit a M2 screw and nut to either side of the lever. This will allow you to move the valve gear between Forward, Reverse and Mid-Gear. The exact position of these screws can be determined by running the chassis or loco

on blocks and moving the lever as it is running until the optimum position is found.

The assembly should be securely fixed to the chassis or footplate using the M3 brass screws so that the valve-gear is held firmly in gear. The reversing lever should be fitted so that the reversing lever arm and the push rod connector are facing towards the inside of the cab - they will foul on the cab side if fitted the other way around. If a ROUNDHOUSE body kit is to be used, mounting holes are provided on the cab footplate so, to test run the chassis at this stage, simply clamp the end of the reversing rod to the chassis as previously described.

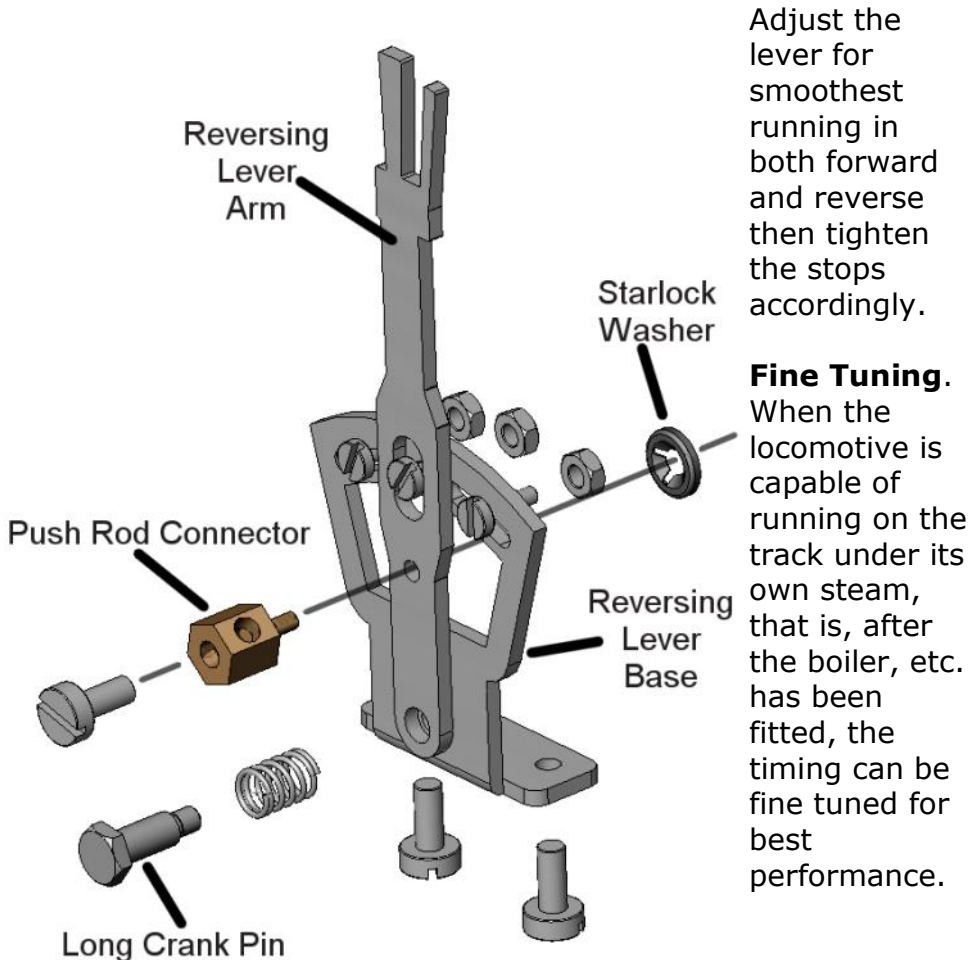

Please note that it will require running under steam for several hours before it reaches its best performance. At ROUNDHOUSE, every engine we build is run at the chassis stage for at least 8 hours in both forwards and reverse. This is because all the working parts have to 'bed in' properly. Initially, steam will leak past the slide valves to a greater or lesser extent, but this will eventually stop as the two surfaces 'bed in' and form a good working seal. The first few hours of running therefore may be a little stiff and jerky at slow speeds and lacking in power.

It is a good idea to run the chassis supported on blocks for a couple of hours before progressing to the track test and adjustments. Use plenty of oil on all working parts.

Set the loco off on a reasonably level length of track at a slow speed. If it stalls, note the position of the drive crank pins if either is at front or rear dead centre. Repeat this several times and it will soon show up if there is a 'dead spot' at any particular point of the valve cycle. If, for instance, it keeps stalling with one particular crank pin just after rear dead centre then this would indicate that the slide valve is opening a little late. Disconnect the radius rod and rotate the valve spindle half a turn to move the slide-valve forwards a fraction as detailed in valve timing earlier. Re-connect the radius rod and try the loco again in both directions to check that your adjustment has not simply removed that dead spot only to replace it with a different one. A short time spent running the engine and making any adjustments just half a turn of the valve spindle at a time should soon show its optimum positions.

Rear Pony Truck

This is provided assembled with a 32mm bogie wheel set fitted. A 45mm bogie set is provided in case you require that. To replace the wheel set remove the steel screw that holds the keeper plate in place. The 32mm wheel set can now be removed and replaced with the 45mm set. To secure the 45mm bogie wheel set use the larger keeper plate provided. The pony truck assembly is then attached to the frame spacer just to the rear of the driving wheels, as shown in the bottom drawing opposite.

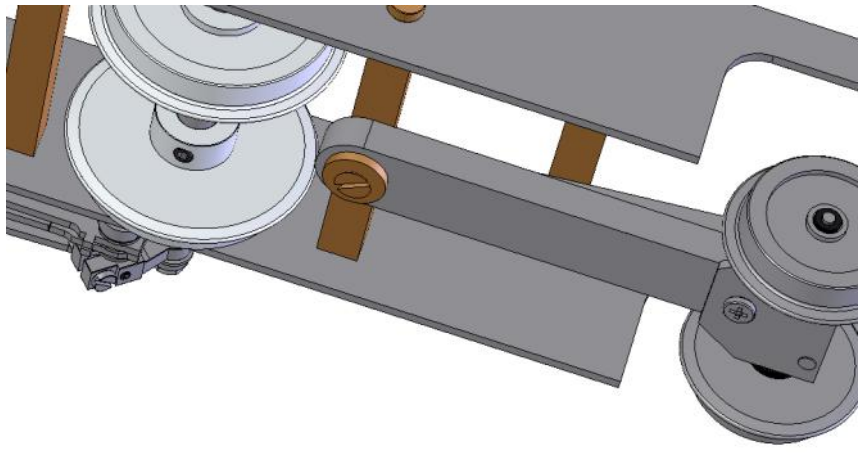
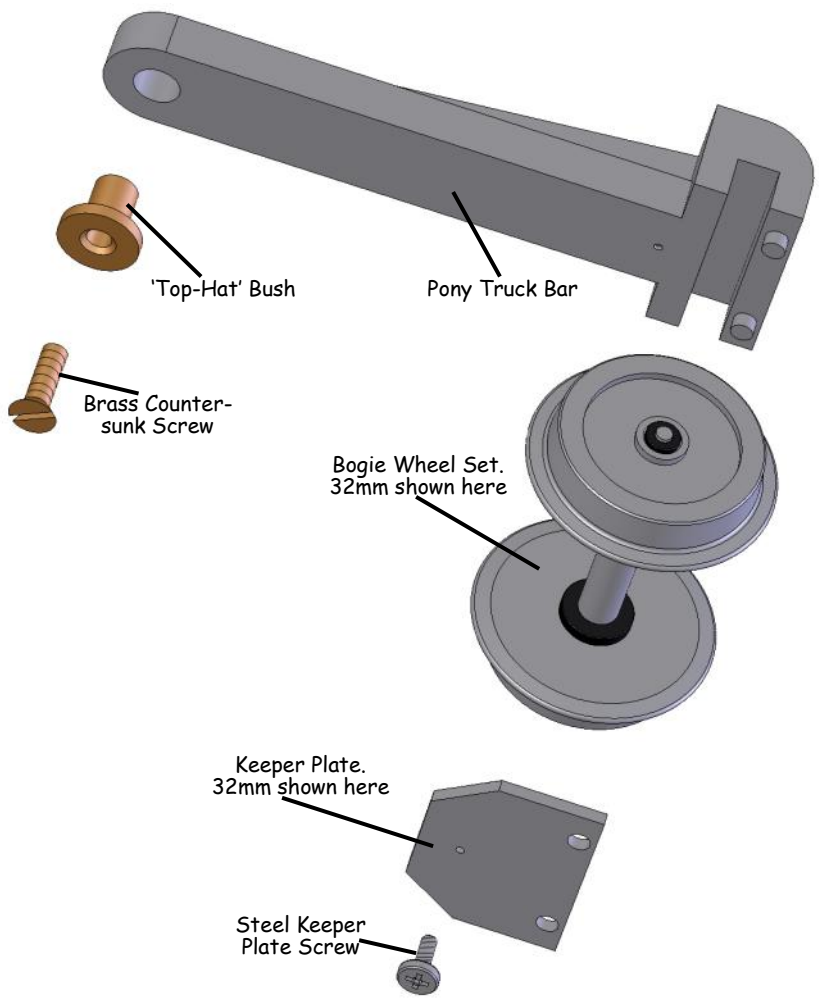

Radio Control

This valve-gear is ideal for operation by radio control and a kit of parts is available for full two channel (reverser and regulator) operation of the locomotive. If however, you are fitting your own equipment, a suitable horn must be fitted to the servo which gives a very short movement. Remember that the radius rod does not move the full length of the expansion link between forward and reverse. A little trial and error is needed to match this movement to that of the servo.

Maintenance & Trouble Shooting

The following section is only relevant once the boiler is fitted as full testing can only be done under steam.

When new, the cylinders will require running for several hours before they reach their full performance as the slide valve must 'bed in'. A cylinder lubricator must be fitted to ensure that there is an adequate supply of steam oil at all times.

The piston rod and valve spindle glands are fitted with 'O' rings and should not be over-tightened. If a steam leak develops just nip up the gland nut enough to stop the leak and no more. Over-tightening will have an adverse effect on running.

The piston is also fitted with an 'O' ring which can be easily replaced if it becomes worn or damaged.

Cylinder covers are sealed by gaskets, and valve chest joints are sealed by `O` rings. Any leaks which develop here during the first few hours of running can usually be cured by simply tightening the relevant screws. Note that these are small screws and will break if over-tightened - be careful.

Because the slide valves are held onto the port faces by steam pressure, it is possible for small particles of dirt, lime scale etc. which are carried through with the steam, to become lodged between the two and thereby break the seal necessary for operation. This would show up as excess amounts of steam being exhausted up the chimney with a continuous hiss coupled with loss of power or failure to run at all. The remedy is quite

simple and involves removing the valve chest cover, lifting the valve chest just enough to remove the slide valve from the side and cleaning the valve and port face. The valve face can also be 're-made' to remove any score marks etc. by carefully rubbing it on a piece of fine emery paper or whet & dry paper placed on a very flat surface. Make sure that you hold the valve perfectly flat down onto the abrasive and remove a very small amount at a time. Take care not to rotate the valve spindle or nut and replace the slide valve the same way round as it was and there will be no need to reset the valve timing. Squirt a little steam oil into the valve chest as you replace the parts to help lubricate and seal the valve.

If all is operating correctly, when running the locomotive slowly, you should hear the separate beats of the exhaust up the chimney as the valve opens and closes.

If, when hot, the chassis seems to stiffen up, re-check the following because, as stated earlier, expansion can alter the fit of something you thought was OK when cold.

Is there still a little side play in the axles? The outside cranks may be pressing on the axle bushes.

Do the wheels still rotate freely without sticking at front or rear dead centre? The coupling rod holes may need a little more attention with the file.

Technical Help

You should now have a running chassis and a better knowledge of what makes a steam locomotive work. If not, don't despair. ROUNDHOUSE offer technical help over the phone during normal working hours, or email us at
support@roundhouse-eng.com

- we will do our best to get you through any difficulties.

Fowler Chassis Kit

CHECKLIST

- 1 Pair mainframes with axle bushes fitted
- 1 Pair buffer beams
- 1 Steel push rod and Quicklink connector

- 2 Return Cranks with steel screws & nuts fitted.
- 2 Expansion links, expansion link bushes & nuts
- 2 Eccentric rods
- 2 Lifting links
- 2 Roll pins
- 6 5BA steel washers
- 2 Weigh shaft brackets
- 1 Weigh shaft
- 4 M2 steel screws & nuts
- 2 Radius rods
- 2 Lifting arms with grub screws fitted and Allen Key (M3 x 1.5mm).
- 6 Short crank pins
- 2 Starlock washers

- 3 Frame spacers with 3 tapped holes
- 1 Frame spacer with 1 countersunk hole
- 2 Outside cranks with crank pins fitted
- 3 Axles
- 4 Plain outside cranks
- 2 Coupling rods
- 2 Connecting rods
- 1 Wheel back to back gauge and Allen key

- 2 Centre Buffers
- 18 M3 brass screws
- 4 M3 brass nuts
- 4 Short crank pins
- 6 4BA steel CSK screws
- 3 1/4" bore steel washers
- 8 5BA steel washers

- 1 Push Rod Connector, Screw & Starlock
- 1 Stainless Steel spring & Long Crank Pin
- 1 Reversing lever handle
- 1 Reversing lever base
- 3 M2 screws and nuts
- 2 M3 mounting screws

- 1 Pair of Cylinder blocks, inc front cover, piston assembly, slide bar and exhaust pipes fitted
- 4 Socket screws and washers
- 4 Valve chest 'O' rings.
- 2 Valve chest assemblies, inc valve rod and valve nut fitted
- 2 Slide valves
- 2 Steel Valve chest covers
- 8 Brass countersunk valve chest screws
- 2 Crossheads and short crank pins
- 2 Steel 6BA x 1/4" screws
- 1 Allen Key (2.5mm) for cylinder screws

- 1 Pony Truck Assembly, consisting of pony truck bar, 32mm bogie wheel set, 32mm keeper plate, steel screw, 'top-hat' bush and countersunk screw
- 1 45mm bogie wheel set
- 1 45mm keeper plate

- 4 Flanged wheels with grub screws
- 2 Flangeless wheels with grub screws

- 1 Set of BA pressed steel spanners

CHECKED