

HBK8 George Body Kit Checklist

Loose items:-

- 1 Cab Floor.
- 1 Cab Front.
- 1 Cab Back.
- 1 Cab Roof.
- 3 Boiler Band with M2 Long Steel Screw & Nut fitted.
- 1 pair of Right and Left cab/side tanks.
- 1 Brass dome.
- 1 Dummy Roof Vent with sticky pads.

Sealed Pack No.1

- 2 Front tank steps.
- 1 Cab Roof Hinge
- 1 R/C servo mount.
- 1 Dummy Whistle valve casting with fixing nut.
- 1 Brass dummy whistle
- 2 Spectacle Rims.
- 2 Dummy Tank Fillers.
- 4 Handrails

Sealed Pack No.2

- 8 Handrail Knobs
- 13 8BA Nuts
- 4 M3 x 6 Brass Screws - Body Mounting Screws
- 4 M3 brass nuts.
- 2 8BA x 3/16 Countersunk Screws
- 2 M2 x 6 Screws, Washers & Nuts

PARTS CHECKED



Modular Locomotive System Instruction Manual *for* HBK8 George Body Kit

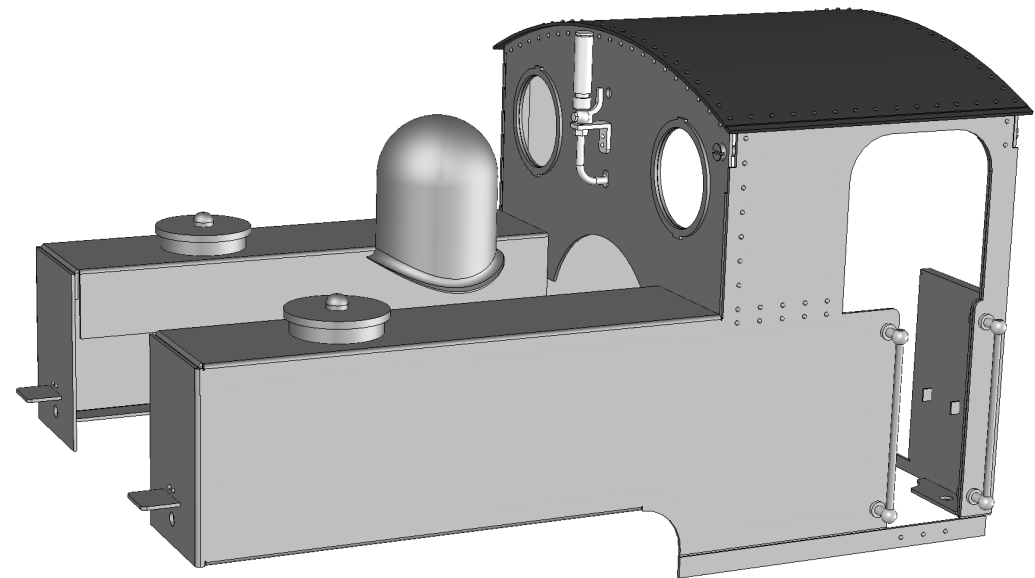

Roundhouse Engineering Co. Ltd.
Units 6-10 Churchill Business Park.
Churchill Road, Wheatley.
Doncaster. DN1 2TF. England.
Tel. 01302 328035 Fax. 01302 761312
Email. mail@roundhouse-eng.com

www.roundhouse-eng.com

HBK32 George Body Kit

Introduction

These instructions cover the construction of the body kit intended to fit the George chassis and boiler kits.

The brass panels are photo etched to shape and all fold lines and holes are etched into the parts where necessary. Only a minimum of cleaning up is required and will normally simply mean running around the edges with a small file or emery cloth to remove any sharp edges or 'pips' that may be left due to the photo etching process. As a general rule, all folds should be 90 degrees with the etched lines on the inside of the angle except if specifically stated otherwise. The kit is designed for either manual or radio control operation and all fixing holes are provided for both versions.

The panels have been designed for assembly with soft solder, however, if preferred holes can be drilled at the joints and small rivets or screws used. If soldering, a small to medium butane blowtorch is ideal, as the large areas of brass will dissipate the heat of a soldering iron too quickly unless a very powerful one is used. Use a suitable flux with the solder, Bakers fluid being particularly good, though extreme care must be taken during use.

Follow the manufacturer's instructions on the packaging of any solder, fluids or glues at all times. Glue of any kind is not suitable for the main structure, but is required for the headlamp lens.

Refer to diagrams where necessary and hold parts together with small clamps such as toolmakers clamps or miniature G or C clamps, during soldering or drilling of joints. It is advisable to run through the full instructions identifying all parts and mountings and have a 'dry run' before soldering anything in place.

All painting is left to the builder and Acrylic paint is readily available in spray cans for a good finish. A good primer is essential and if available an etch primer should be used on brass parts. Read carefully and follow the maker's instructions that appear on the can before using any paint. All parts must be thoroughly cleaned and

The finished body is fastened to the chassis in four places. Two M3 screws pass down through the cab back base flanges and cab footplate with nuts underneath.

Two more pass through the front of the side tanks and the vertical flange on the rear of the front footplate with nuts inside the tanks.

The dummy roof vent is purely a cosmetic addition to the roof and is attached using the double sided sticky pads.

Finally, place the dome over the boiler filler plug.

All assemblies and the brass dome can now be prepared and painted as outlined in the introduction.

When the painted items are thoroughly dry, the four cab handrails can be fitted using 8BA nuts on the inside.

The dummy whistle valve is screwed to the cab front using the nut supplied. The polished brass dummy whistle can then be glued onto the top of the valve.

The dummy tank fillers can be glued in place.

The spectacle rims are held in place by tabs which pass through the slots above and below the spectacles. Note that the top tab on each rim should be bent down inside the cab and the bottom ones bent up.

Finally, the cab roof is attached using the two M2 x 6 screws, washers and nuts. These screws pass through from the outside of the cab with the washers and nuts on the inside of the hinge. Leave them slightly loose to allow the hinge to operate. A spot of 'Loctite' or, if this is not available, paint, on the threads will prevent the nut from coming off.

To open the roof, it should be lifted slightly on the left hand side so that the hinge slides up on it's slotted brackets, and should then hinge open freely.

Check that when closed, it sits squarely on top of the cab and that its curve matches the radius of the spectacle plates on which it sits.

The brass boiler bands should be cleaned to remove any sharp edges and then polished and fitted over the front of the boiler wrapper as follows.

One touching the rear of the smokebox.

One just in front of the dome.

One just in front of the cab spectacle plate.

rubbed down with fine wet and dry paper prior to painting. Be aware that pinholes may be present on the surface of the brass due to the etching process and these should be filled with a metal primer prior to painting.

Construction

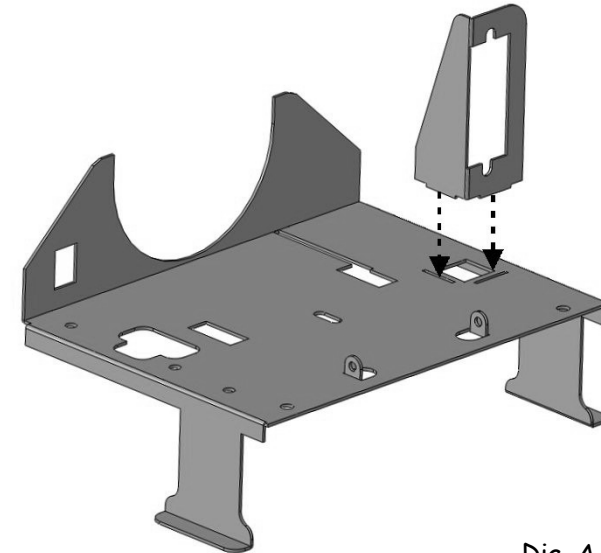

Dia. A

Fold up the cab floor and regulator r/c servo bracket as shown in the diagram (Dia. A). Place the two tabs on the bottom of the servo bracket into the slots on the footplate and fix with soft solder.

General Note.

When folding long sections, i.e. the side flanges, it is better to hold the flanges between two pieces of angle iron in a vice or clamps, as illustrated (Dia. B). In this way, all the flange is bent over in one go and the result is a much neater job.

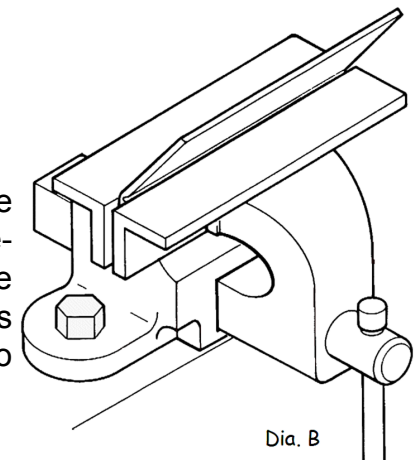

Dia. B

The floor can now be painted then fitted to the chassis as follows.

If the chassis/boiler unit is complete, it is necessary to remove the lubricator, gas burner and gas tank and the screw fixing the rear boiler mounting foot to the frame spacer.

Pull the boiler backwards out of the smoke box then lift the rear end and slide the foot plate in place.

Reposition the boiler and fasten again with the screw up through the rear frame spacer and into the mounting foot, this time also passing through the hole (1 on Dia. C) in the foot plate.

The mounting hole is slotted to allow the foot plate to be squared up to the rear buffer beam before finally tightening the screw from underneath.

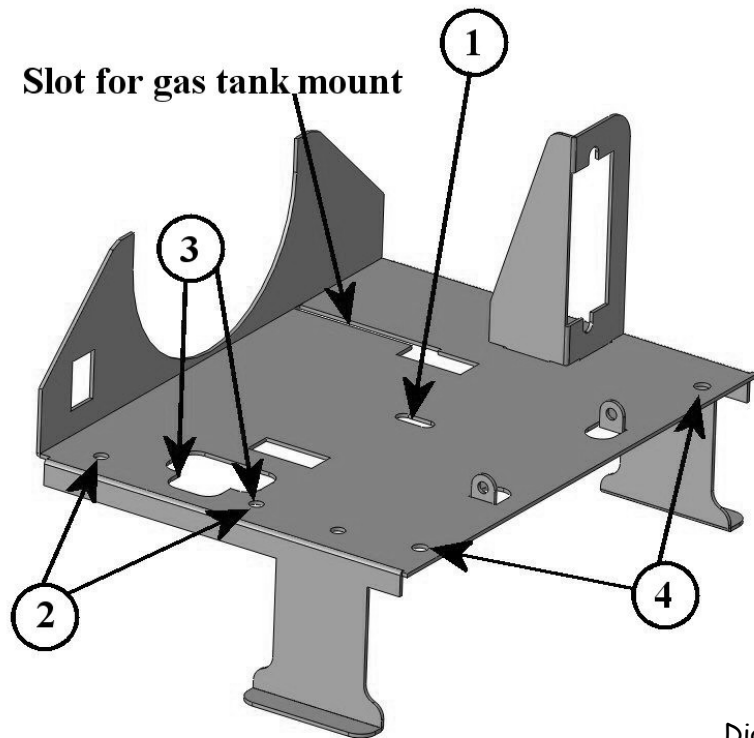

Dia. C

The cab roof can now be assembled.

Fold the cab roof hinge as shown in the picture below, and attach it to the underside of the cab roof using two 8BA x 3/16 countersunk screws and nuts. The holes on the top of the roof that these screws pass through are countersunk, so that the head of the screw is flat with the roof. The hinge has slotted holes to allow for adjustment of the roof position. Check roof and hinge position on top of the cab and tighten the screws up. File away any excess thread that protrudes through the nut plus about half the thickness of the nut as well.

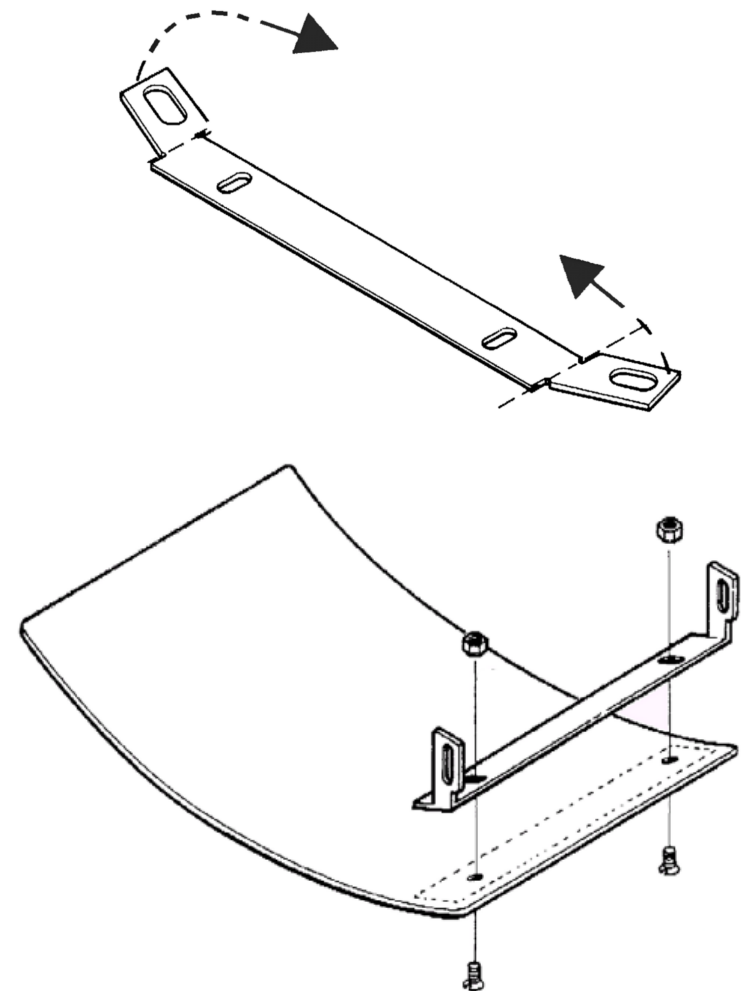

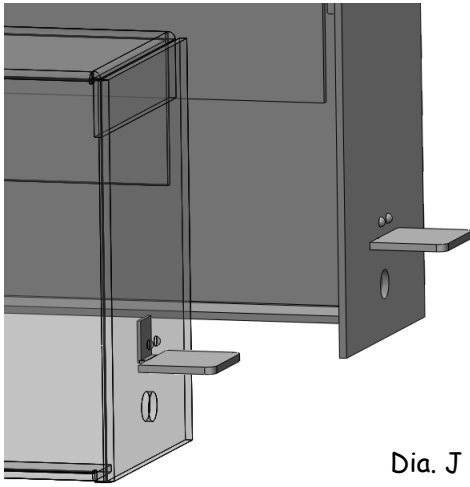

Dia. J

The side tank front steps can now be fitted. Push the half etched tab through the slot in the tank front and bend it up on the inside then solder.

Two lamp brackets are provided which can be fixed to the cab rear if required. Remove the two side tabs from each bracket and fold as shown in dia. K. The brackets can now be laid on or clamped in place and soldered to the cab back in a position to suite your needs.

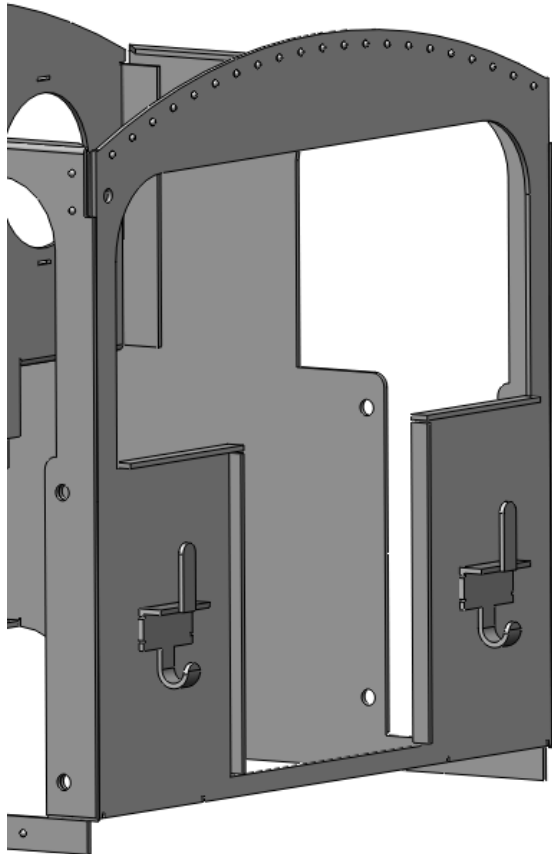

Dia. K

Replace the gas equipment and lubricator as before. Note that there is a slot in the foot plate for the gas tank mounting to pass through.

Two holes (3 on dia. C) are provided on the left hand side of the foot plate for mounting the manual reversing lever. The front screw is used with a large brass washer and so that the washer clamps under the edge of the large cut-out in the floor.

Diagram D shows the basic layout of controls and fittings on a manual control engine. Radio control versions differ slightly but this is covered in detail in the R/C fittings kit instruction manual.

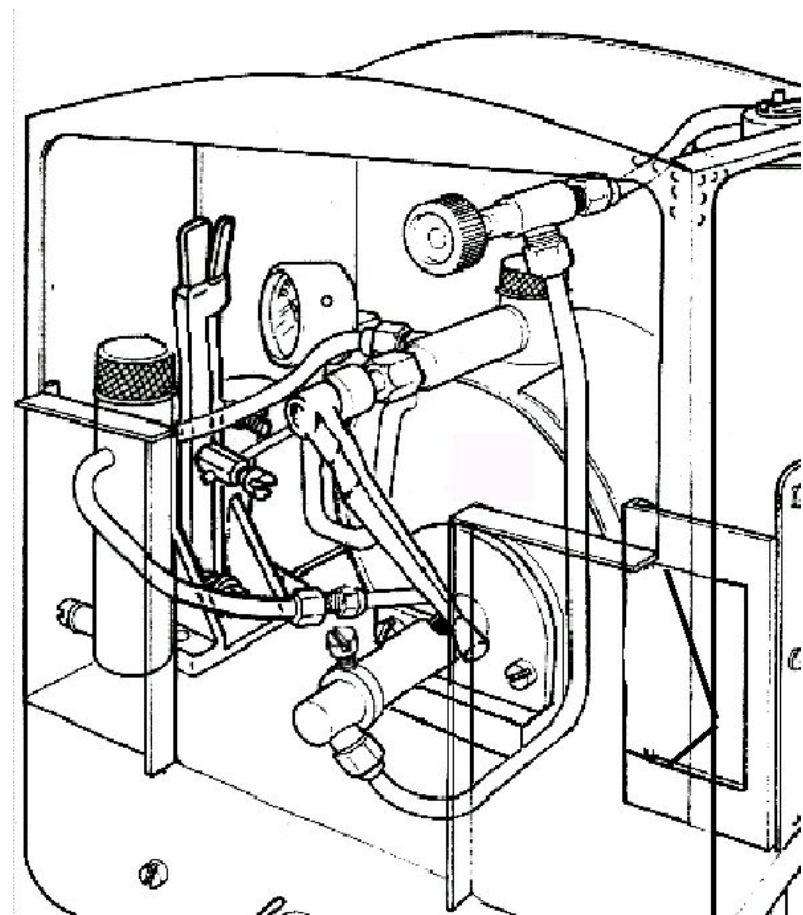

Dia. D

Fold up left and right hand body sides as shown in Dia. E, ensuring that all folds are at 90 degrees. Clamp together tab A and the tank front and solder the two together making sure that the tank top is at 90 degrees to the tank side.

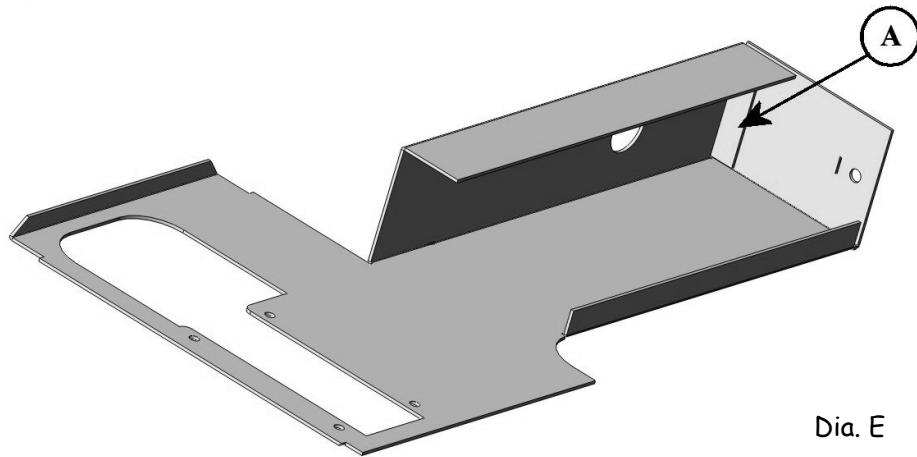

Dia. E

Fold up the cab back as shown in dia. F.

Note that four large flanges with holes in bend the same way, i.e. facing into the cab interior however, the four narrow flanges (B) fold the opposite way and point outwards.

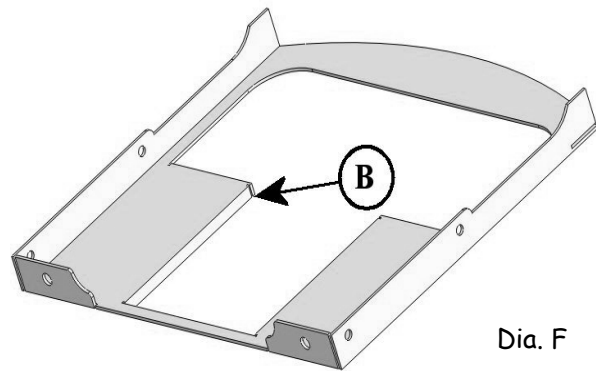

Dia. F

Fold up the cab front as shown in dia. G.

Note that the two side flanges bend one way, i.e. facing into the cab interior however, the two bottom flanges fold the opposite way.

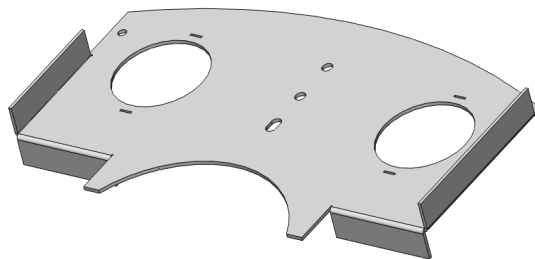

Dia. G

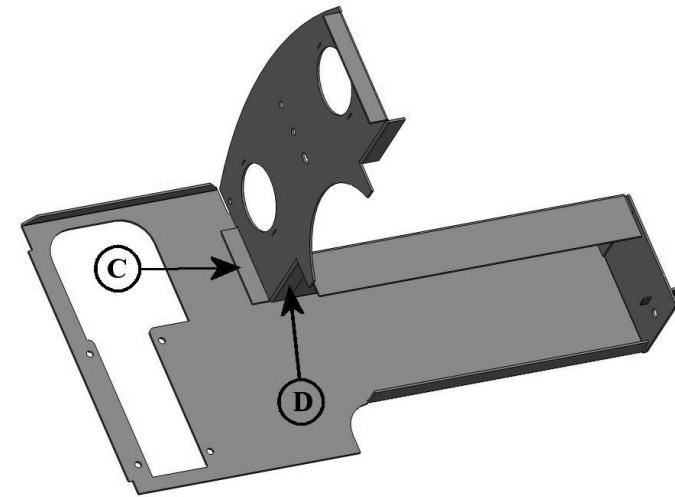

Dia. H

Clamp tabs C and D (dia.H) on the cab front to the left hand cab side and underside of tank top, ensuring that all faces are at 90 degrees to each other, then solder both joints. A slot will be left at the top for the roof hinge. Repeat for the right hand side.

Clamp tab E (dia. I) on the cab back to the cab side ensuring that the handrail holes line up and the back face is parallel to the back edge of the cab before soldering. Repeat for other side. As with the front panel, a slot is formed in the top left hand corner for the roof hinge.

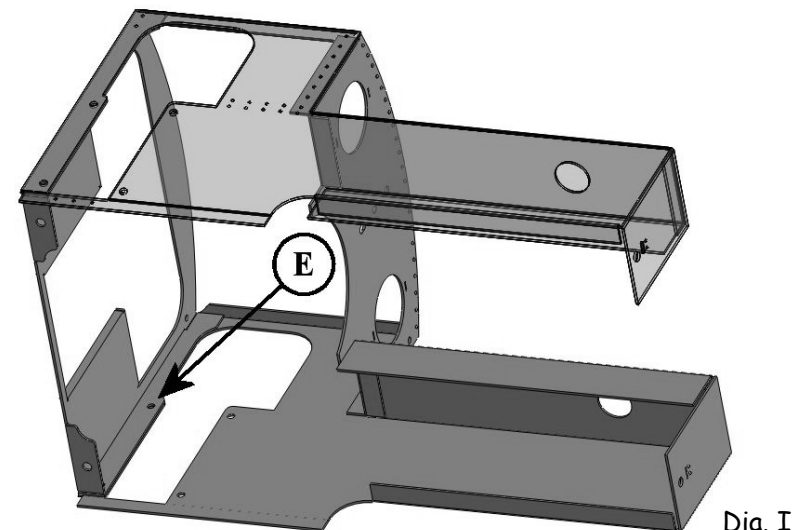

Dia. I